

**A G E N D A**  
**JAMES CITY COUNTY CHESAPEAKE BAY BOARD**  
**REGULAR MEETING**  
**County Government Center, Building F**  
**101 Mounts Bay Road, Williamsburg, Virginia 23188**  
**July 14, 2021**  
**5:00 PM**

---

**A. CALL TO ORDER**

**B. ROLL CALL**

**C. MINUTES**

1. Minutes from June 9, 2021 Regular Meeting

**D. PUBLIC HEARINGS**

1. Case No. CBPA 21-0064 : 101 Abigail Lane
2. Case No. CBPA 21-0083 : 114 Constance Avenue
3. Case No. CBPA 21-0087 : 10007 Sycamore Landing Road
4. Case No. CBPA 21-0075 : 10006 Sycamore Landing Road

**E. BOARD CONSIDERATIONS**

**F. MATTERS OF SPECIAL PRIVILEGE**

**G. ADJOURNMENT**

**ITEM SUMMARY**

DATE: 6/30/2021  
TO: Chesapeake Bay Board  
FROM: Trevor Long, Watershed Planner  
SUBJECT: Minutes from June 9, 2021 Regular Meeting

---

**ATTACHMENTS:**

	Description	Type
📎	Minutes	Minutes

**REVIEWERS:**

Department	Reviewer	Action	Date
Chesapeake Bay Group	Woolson, Michael	Approved	7/6/2021 - 10:45 PM
Chesapeake Bay Group	Small, Toni	Approved	7/7/2021 - 7:53 AM
Publication Management	Daniel, Martha	Approved	7/7/2021 - 8:57 AM
Chesapeake Bay Group	Secretary, ChesBay	Approved	7/7/2021 - 4:01 PM

**MINUTES**  
**JAMES CITY COUNTY CHESAPEAKE BAY BOARD**  
**REGULAR MEETING**  
**County Government Center, Building F**  
**101 Mounts Bay Road, Williamsburg, Virginia 23188**  
**June 9, 2021**  
**5:00 PM**

---

**A. CALL TO ORDER**

The Chesapeake Bay Board meeting for June 9, 2021, was called to order.

The responsibility of this Board is to carry out locally the Commonwealth policy to protect against and minimize pollution and deposition of sediment in wetlands, streams, and lakes in James City County, which are tributaries of the Chesapeake Bay.

**B. ROLL CALL**

**Board Members Present:**

David Gussman, Chairman  
William Apperson  
Larry Waltrip  
Michael O'Brien

**Board Members Absent:**

Charles Roadley  
Halle Dunn

**Other Staff Present:**

Toni Small, Director, Stormwater and Resource Protection  
Liz Parman, Assistant County Attorney  
Michael Woolson, Resource Protection Section Chief, Stormwater and Resource Protection  
Trevor Long, Watershed Planner, Stormwater and Resource Protection  
Robin Benedict, Watershed Planner, Stormwater and Resource Protection  
Janice Petty, Stormwater Assistant, Stormwater and Resource Protection

**C. MINUTES**

1. Minutes from May 12, 2021, Regular Meeting

A motion to Approve the minutes was made by Mr. Gussman. The minutes were approved on a voice vote.

**D. PUBLIC HEARINGS**

1. Case No. CBPA 21-0064 : 101 Abigail Lane

The Applicant requested that the case be deferred until the July 14, 2021, meeting.

2. Case No. CBPA 21-0065 : 111 Cove Road

Mr. Trevor Long, Watershed Planner, presented the exception request submitted by Mr. Joseph and Mrs. Katherine Dvorak, for encroachments into the Resource Protection Area (RPA) buffer for the construction of a patio and steps located at 111 Cove Road within The Kingspoint subdivision and the College Creek watershed. The property is further identified as James City County Tax Map Parcel No. 4910240009. The presentation described the current and proposed site conditions. If the Board approved the request, staff asked that the suggested conditions be incorporated into the approval.

The Board deliberated the pros and cons of this application.

Mr. Gussman opened the Public Hearing.

**A.** Mr. Joseph Dvorak, outlined the project for the Board.

Mr. Gussman closed the Public Hearing, as no one else wished to speak.

Mr. Apperson made a motion to Adopt the resolution for Chesapeake Bay Board Case No. CBPA 21- 0065 at 111 Cove Road.

A motion to Approve with Conditions was made by Mr. Apperson, the motion result was:

AYES: 4 NAYS: 0 ABSTAIN: 0 ABSENT: 2

AYES: Gussman, Apperson, Waltrip, O'Brien

NAYS: None

ABSENT: Roadley, Dunn

3. Case No. CBPA 21-0073 : 205 St. Cuthbert

Mr. Trevor Long, Watershed Planner, presented the exception request submitted by Ms. Autumn Hauser, Williams Landscape and Design, Inc., on behalf of Mr. James Mullins for encroachments into the RPA buffer for the construction of a patio and walkway located at 205 St. Cuthbert within the Ford's Colony Subdivision and the Powhatan Creek watershed. The property is further identified as James City County Tax Map Parcel No. 3721000053. The presentation described the current and proposed site conditions. If the Board approved the request, staff asked that the suggested conditions be incorporated into the approval.

The Board deliberated the pros and cons of this application.

Mr. Gussman inquired about the lake being a Best Management Practice (BMP).

Mr. Long affirmatively replied.

Mr. Gussman inquired of the composition of the walkways.

Mr. Long replied that there are two walkways with this plan. One pathway comes around the side of the house and will be made of pavers. The walkway extending down to the firepit and seating area will be composed of gravel.

Mr. Gussman opened the Public Hearing.

**A.** Mr. James Mullins, owner, outlined the project for the Board.

**B.** Mr. Aaron Williams, Williams Landscape and Design, Inc., was available to answer questions from the Board.

Mr. Gussman closed the Public Hearing, as no one else wished to speak.

Mr. O'Brien made a motion to Adopt the resolution for Chesapeake Bay Board Case No. CBPA 21-0073 at 205 St. Cuthbert.

A motion to Approve with Conditions was made by Mr. O'Brien, the motion result was:

AYES: 4 NAYS: 0 ABSTAIN: 0 ABSENT: 2

AYES: Gussman, Apperson, Waltrip, O'Brien

NAYS: None

ABSENT: Roadley, Dunn

4. Case No. CBPA 21-0072 : 1909 North Fowlers Close

Mr. Michael Woolson, Resource Protection Section Chief, presented the exception request submitted by Ms. Autumn Hauser, Williams Landscape and Design, Inc., on behalf of Ms. Kristen Elder and Mr. Kent Saunders for encroachments into the RPA buffer for the construction and installation of a pool and patio located at 1909 North Fowlers Close within the Fowler's Lake at The Governor's Land Subdivision and the Gordon Creek watershed. The property is further identified as James City County Tax Map Parcel No. 4320400015. The presentation described the current and proposed site conditions. If the Board approved the request, staff asked that the suggested conditions be incorporated into the approval.

The Board deliberated the pros and cons of this application.

Mr. Gussman opened the Public Hearing.

A. Mr. Aaron Williams, Williams Landscape and Design, Inc., outlined the project for the Board.

Mr. Gussman closed the Public Hearing, as no one else wished to speak.

Mr. Waltrip made a motion to Adopt the resolution for Chesapeake Bay Board Case No. CBPA 21-0072 at 1909 North Fowlers Close.

A motion to Approve with Conditions was made by Mr. Waltrip, the motion result was:

AYES: 4 NAYS: 0 ABSTAIN: 0 ABSENT: 2

AYES: Gussman, Apperson, Waltrip, O'Brien

NAYS: None

ABSENT: Roadley, Dunn

5. Case No. CBPA 21-0067 : 1796 Cypress Isle

Mr. Trevor Long, Watershed Planner, presented the exception request submitted by Ms. Autumn Hauser, Williams Landscape and Design, Inc., on behalf of Ms. Brenda Snow for encroachments into the RPA buffer for the construction of a landing located at 1796 Cypress Isle within The Governors Land subdivision and the Powhatan Creek watershed. The property is further identified as James City County Tax Map Parcel No. 4321400006. The presentation described the current and proposed site conditions. If the Board approved the request, staff asked that the suggested conditions be incorporated into the approval.

The Board deliberated the pros and cons of this application.

Mr. Gussman opened the Public Hearing.

A. Mr. Aaron Williams, Williams Landscape and Design, Inc., outlined the project for the Board. Permeable pavers will be used for the pathway.

Mr. Gussman closed the Public Hearing, as no one else wished to speak.

Mr. Apperson made a motion to Adopt the resolution for Chesapeake Bay Board Case No. CBPA 21-0067 at 1796 Cypress Isle.

A motion to Approve with Conditions was made by Mr. Apperson, the motion result was:  
AYES: 4 NAYS: 0 ABSTAIN: 0 ABSENT: 2  
AYES: Gussman, Apperson, Waltrip, O'Brien  
NAYS: None  
ABSENT: Roadley, Dunn

**E. BOARD CONSIDERATIONS**

Mr. Woolson noted the upcoming Wetlands and Chesapeake Bay Board Meetings on July 14, 2021.

**F. MATTERS OF SPECIAL PRIVILEGE**

1. Remote participation policy.
2. Thank you to Mr. Mitchell Anderson for technical assistance for remote participation.
3. Thank you to Mr. Trevor Long for his excellent job conducting the May 12, 2021 Board meeting.

**G. ADJOURNMENT**

A motion to Adjourn was made by Mr. Gussman and approved on a voice vote.  
The meeting adjourned at 6:49 p.m.

**ITEM SUMMARY**

DATE: 6/30/2021  
TO: Chesapeake Bay Board  
FROM: Trevor Long, Watershed Planner  
SUBJECT: Case No. CBPA 21-0064: 101 Abigail Lane

---

CBPA 21-0064: Ms. Susan Maida has filed an exception request for encroachments into the resource protection area (RPA) buffer for the construction of a retaining wall at 101 Abigail Lane, JCC Parcel ID No. 5030400082.

**ATTACHMENTS:**

	Description	Type
☐	Staff Report	Staff Report
☐	Resolution	Resolution
☐	Adjacent Property Owner Letter	Backup Material
☐	Adjacent Property Owner List	Backup Material
☐	Memo	Backup Material

**REVIEWERS:**

Department	Reviewer	Action	Date
Chesapeake Bay Group	Woolson, Michael	Approved	7/6/2021 - 10:46 PM
Chesapeake Bay Group	Small, Toni	Approved	7/7/2021 - 7:52 AM
Publication Management	Daniel, Martha	Approved	7/7/2021 - 8:29 AM
Chesapeake Bay Group	Secretary, ChesBay	Approved	7/7/2021 - 4:00 PM

**CHESAPEAKE BAY BOARD EXCEPTION No. CBPA 21-0064. 101 Abigail Lane  
Staff Report for the July 14, 2021, Chesapeake Bay Board Public Hearing**

---

*This staff report is prepared by the James City County Stormwater and Resource Protection to provide information to the Chesapeake Bay Board to assist them in making a recommendation on this assessment. It may be useful to members of the general public interested in this assessment.*

---

**EXISTING SITE DATA AND INFORMATION**

Applicant: Ms. Susan Maida

Agent: Mr. Jesse McHose, Extra Mile Landscapes Inc.

Location: 101 Abigail Lane

Parcel Identification No.: 5030400082

Parcel: Lot 82, Phase 2, Tazwell's Hundred

Lot Size: 0.46 acres

Area of Lot in Resource Protection Area (RPA): 0.32 acres +/- (70%)

Watershed: College Creek (HUC JL 34)

Floodplain: None affecting this property

Proposed Activity: Construction of a retaining wall

Impervious Cover: 105 square feet

RPA Encroachment: 105 square feet, landward 50-foot RPA

Staff Contact: Trevor A. Long, Watershed Planner Phone: 253-6789

**BRIEF SUMMARY AND DESCRIPTION OF ACTIVITIES**

Mr. Jesse McHose, Extra Mile Landscapes Inc., has applied for a Chesapeake Bay Exception on behalf of Ms. Susan Maida for encroachments into the RPA buffer for the construction of a retaining wall on property located at 101 Abigail Lane within the Kingsmill subdivision and the College Creek watershed. The property is further identified as James City County Tax Map Parcel No. 5030400082. The parcel was platted in 1981, prior to the adoption of the Chesapeake Bay Preservation Ordinance in 1990.

The total lot size of this property is 0.46 acres, of which 70% is located within the RPA. The applicant is proposing to construct a retaining wall to the rear of the existing house equating to approximately 105 square feet of impacts to the landward 50-foot RPA. The applicant has expressed concerns regarding erosion behind the house and proposed a retaining wall to protect the property. It should be noted that the retaining wall shall be constructed on the owner's property unless permission is granted from the adjacent property owner. County mitigation requirements for the proposed amount of impervious impacts to the RPA equates to the plantings of three shrubs.



## **STAFF EVALUATION**

Staff has evaluated the application and exception request for the construction of a retaining wall. This application meets the Ordinance conditions in Sections 23-11 and 23-14 and should be heard by the Board because the construction of a retaining wall is considered accessory in nature.

## **CONSIDERATION BY THE CHESAPEAKE BAY BOARD**

The Board may grant exceptions to Section 23-7 if the application meets the following five conditions:

1. The exception request is the minimum necessary to afford relief; and
2. Granting the exception will not confer upon the Applicants any special privileges denied by Chapter 23, Chesapeake Bay Preservation, of the James City County Code, to other property owners similarly situated in the vicinity; and
3. The exception request will be in harmony with the purpose and intent of Chapter 23 of the James City County Code and is not of substantial detriment to water quality; and
4. The exception request is not based on conditions or circumstances that are self-created or self-imposed, nor does the request arise from conditions or circumstances, either permitted or non-conforming that are related to adjacent parcels; and
5. Reasonable and appropriate conditions are imposed which will prevent the exception request from causing a degradation of water quality.

## **STAFF RECOMMENDATIONS**

Staff has reviewed the application and exception request and has determined the impacts associated with the proposal to be minor for the proposed development. Staff recommends approval for this exception request and if the Board wishes to approve this request, staff recommends the following conditions be incorporated into the approval:

1. The applicant must obtain all other necessary federal, state, and local permits as required for the project, including a building permit if necessary; and
2. The submittal of a mitigation plan equating to three shrubs be submitted to the Stormwater and Resource Protection Division; and
3. A surety of \$250 be submitted in a form acceptable to the James City County Attorney's Office to guarantee the mitigation plantings; and
4. This exception request approval shall become null and void if construction has not begun by July 14, 2022; and
5. Written requests for an extension to an exception shall be submitted to the Stormwater and Resource Protection Division no later than June 2, 2022, six weeks prior to the expiration date.

TAL/md  
CBPA21-64\_101AbigailLn

Attachments:

1. Resolution
2. Site Plan

## RESOLUTION

CASE NO. CBPA 21-0064. 101 ABIGAIL LANE

### JAMES CITY COUNTY CHESAPEAKE BAY PRESERVATION ORDINANCE EXCEPTION

WHEREAS, Ms. Susan Maida (the “Applicant”) has applied to the Chesapeake Bay Board of James City County (the “Board”) on July 14, 2021, to request an exception to use the Resource Protection Area (the “RPA”) on a parcel of property identified as James City County Real Estate Tax Map Parcel No. 5030400082 and further identified as 101 Abigail Lane (the “Property”) as set forth in the application CBPA 21-0064 for the purpose of construction of a retaining wall; and

WHEREAS, the Board has listened to the arguments presented and has carefully considered all evidence entered into the record.

NOW, THEREFORE, BE IT RESOLVED that the Chesapeake Bay Board of James City County, Virginia, following a public hearing, by a majority vote of its members FINDS that:

1. The exception request is the minimum necessary to afford relief.
2. Granting the exception will not confer upon the Applicants any special privileges denied by Chapter 23, Chesapeake Bay Preservation, of the James City County Code, to other property owners similarly situated in the vicinity.
3. The exception request will be in harmony with the purpose and intent of Chapter 23 of the James City County Code and is not of substantial detriment to water quality.
4. The exception request is not based on conditions or circumstances that are self-created or self-imposed, nor does the request arise from conditions or circumstances either permitted or non-conforming that are related to adjacent parcels.
5. Reasonable and appropriate conditions are hereby imposed, as set forth below, which will prevent the exception request from causing a degradation of water quality.
6. In granting this exception, the following conditions are hereby imposed to prevent this exception request from causing degradation of water quality:
  - a. The applicant must obtain all other necessary federal, state, and local permits as required for the project, including a building permit if necessary; and
  - b. The submittal of a mitigation plan equaling three shrubs be submitted to the Stormwater and Resource Protection Division; and
  - c. A surety of \$250 be submitted in a form acceptable to the James City County Attorney’s Office to guarantee the mitigation plantings; and

- d. This exception request approval shall become null and void if construction has not begun by July 14, 2022; and
- e. Written requests for an extension to an exception shall be submitted to the Stormwater and Resource Protection Division no later than June 2, 2022, six weeks prior to the expiration date.

---

David Gussman  
Chair, Chesapeake Bay Board

---

Michael D. Woolson  
Secretary to the Board

Adopted by the Chesapeake Bay Board of James City County, Virginia, this 14th day of July, 2021.

CBPA21-64\_101AbigailLn-res



**General Services**  
107 Tewning Road  
Williamsburg, VA 23188  
P: 757-259-4080  
General.Services@jamescitycountyva.gov  
[jamescitycountyva.gov](http://jamescitycountyva.gov)

**Capital Projects**  
107 Tewning Road  
Williamsburg, VA 23188  
757-259-4080

**Fleet**  
103 Tewning Road  
Williamsburg, VA 23188  
757-259-4122

**Stormwater and  
Resource Protection**  
101-E Mounts Bay Road  
Williamsburg, VA 23185  
757-253-6670

**Facilities & Grounds**  
113 Tewning Road  
Williamsburg, VA 23188  
757-259-4080

**Solid Waste**  
1204 Jolly Pond Road  
Williamsburg, VA 23188  
757-565-0971

May 19, 2021

RE: CBPA 21-0064  
101 Abigail Lane  
Retaining Wall

Dear Adjacent Property Owner:

In accordance with State and County Codes, this letter is to notify you that a request has been filed with the James City County Chesapeake Bay Board by Ms. Susan Maida for encroachment into the Resource Protection Area (RPA) buffer for the construction of a retaining wall. The project is located at 101 Abigail Lane and further identified as JCC Parcel No. 5030400082.

A complete description, plan and other information are on file in the Stormwater and Resource Protection Division and are available for inspection during normal business hours, should anyone desire to review them.

The Chesapeake Bay Board will hold an advertised public hearing on **Wednesday, June 9, 2021 at 5:00 p.m.**, in the Board Room of Building F, 101 Mounts Bay Road, James City County, Virginia, at which time you may request to speak on the above referenced project.

Sincerely,

*Michael D. Woolson*

Michael D. Woolson  
Chesapeake Bay Board Secretary  
757-253-6823  
michael.woolson@jamescitycountyva.gov

MDW: jep

Mailing List for: CBPA-21-0064–101 Abigail Lane:- Retaining Wall

Owner: 5030400082

Maida, Susan Jean, Trustee  
101 Abigail Lane  
Williamsburg, VA 23185-6506

5030400112

Kitchens, Theodore S & Nancy C  
601 E Tazewells Way  
Williamsburg, VA 23185-6519

5030400083

Martens, Amber  
105 Abigail Lane  
Williamsburg, VA 23185-6506

5030400032

Hart, Bradford M & Amy F  
224 W Tazewells Way  
Williamsburg, VA 23185-6524

5030400088 – 100 Abigail Lane

Manfredonia, Fred & Sharyn R  
22 Monarch Way  
Kinnelon, NJ 07405-2981

5030400113

Weideman, J Mark & Crowley, Pamela K  
501 E Tazewells Way  
Williamsburg, VA 23185-6517

5030400081

Richardson, Joseph L  
512 E Tazewells Way  
Williamsburg, VA 23185-6516

5030400080

Collins, Daniel R & Elizabeth M  
508 E Tazewells Way  
Williamsburg, VA 23185-6516

## MEMORANDUM

DATE: June 9, 2021

TO: The Chesapeake Bay Board

FROM: Michael Woolson, Section Chief, Resource Protection

SUBJECT: Chesapeake Bay Exception No. CBPA-21-0064. 101 Abigail Lane

---

Ms. Susan Maida has requested a deferral of this application for exception to the Chesapeake Bay Preservation Ordinance while the site plan is finalized for the project. Staff concurs with this request. As this case has been public noticed, staff recommends that the public hearing be opened and stay open until the July meeting, at which time the case will be heard.

**ITEM SUMMARY**

DATE: 7/14/2021  
TO: Chesapeake Bay Board  
FROM: Trevor Long, Watershed Planner  
SUBJECT: Case No. CBPA 21-0083 : 114 Constance Avenue

---

CBPA 21-0083: Acelution, Inc., on behalf of Mr. Stephen and Ms. Jessica Smith, has filed an exception request for encroachments into the RPA buffer for the construction of a landing at 114 Constance Avenue, JCC Parcel ID No. 4730500026.

**ATTACHMENTS:**

	Description	Type
☐	Staff Report	Staff Report
☐	Resolution	Resolution
☐	Site Plan	Exhibit
☐	Adjacent Property Owner Letter	Backup Material
☐	Adjacent Property Owner List	Backup Material
☐	Public Advertisement	Backup Material

**REVIEWERS:**

Department	Reviewer	Action	Date
Chesapeake Bay Group	Woolson, Michael	Approved	7/6/2021 - 10:46 PM
Chesapeake Bay Group	Small, Toni	Approved	7/7/2021 - 7:52 AM
Publication Management	Daniel, Martha	Approved	7/7/2021 - 8:44 AM
Chesapeake Bay Group	Secretary, ChesBay	Approved	7/7/2021 - 4:00 PM

**CHESAPEAKE BAY BOARD EXCEPTION No. CBPA 21-0083. 114 Constance Avenue  
Staff Report for the July 14, 2021, Chesapeake Bay Board Public Hearing**

---

*This staff report is prepared by the James City County Stormwater and Resource Protection to provide information to the Chesapeake Bay Board to assist them in making a recommendation on this assessment. It may be useful to members of the general public interested in this assessment.*

---

**EXISTING SITE DATA AND INFORMATION**

Applicants: Mr. Stephen and Ms. Jessica Smith  
Agent: Ms. Brittany Hulstine, Acelution, Inc.  
Location: 114 Constance Avenue  
Parcel Identification No.: 4730500026  
Parcel: Lot 26, Section 1, Powhatan Shores  
Lot Size: 0.55 acres  
Area of Lot in Resource Protection Area (RPA): 0.24 acres +/- (44%)  
Watershed: Powhatan Creek (HUC JL 31)  
Floodplain: Zone AE - Base flood elevation determined at 7 feet  
Proposed Activity: Construction of a landing  
Impervious Cover: 495 square feet  
RPA Encroachment: 495 square feet, seaward 50-foot RPA  
Staff Contact: Trevor A. Long, Watershed Planner Phone: 253-6789

**BRIEF SUMMARY AND DESCRIPTION OF ACTIVITIES**

Ms. Brittany Hulstine, Acelution, Inc., has applied for a Chesapeake Bay Exception on behalf of Mr. Stephen and Ms. Jessica Smith for encroachments into the RPA buffer for the construction of a landing on property located at 114 Constance Avenue within the Powhatan Shores subdivision and the Powhatan Creek watershed. The property is further identified as James City County Tax Map Parcel No. 4730500026. The parcel was platted in 1975, prior the adoption of the Chesapeake Bay Preservation Ordinance in 1990.

The total lot size of this property is 0.55 acres, of which 44% is located within the RPA. The applicants are proposing to construct a landing towards the rear of the existing house equaling approximately 495 square feet of impacts to the seaward 50-foot RPA. The property has an existing retaining wall and staircase leading to a dock and boatlift on-site. The applicants are proposing to construct the landing between the existing retaining wall and bulkhead for the purpose of seating. Required mitigation of this amount of impervious impacts to the RPA equals the plantings of one planting unit (one canopy tree, two understory trees, and three shrubs).

**STAFF EVALUATION**

Staff has evaluated the application and exception request for the construction of a landing. This application meets the Ordinance conditions in Sections 23-11 and 23-14 and should be heard by the Board because the construction of a landing is considered accessory in nature.



## **CONSIDERATION BY THE CHESAPEAKE BAY BOARD**

The Board may grant exceptions to Section 23-7 if the application meets the following five conditions:

1. The exception request is the minimum necessary to afford relief; and
2. Granting the exception will not confer upon the Applicants any special privileges denied by Chapter 23, Chesapeake Bay Preservation, of the James City County Code, to other property owners similarly situated in the vicinity; and
3. The exception request will be in harmony with the purpose and intent of Chapter 23 of the James City County Code and is not of substantial detriment to water quality; and
4. The exception request is not based on conditions or circumstances that are self-created or self-imposed, nor does the request arise from conditions or circumstances, either permitted or non-conforming that are related to adjacent parcels; and
5. Reasonable and appropriate conditions are imposed which will prevent the exception request from causing a degradation of water quality.

## **STAFF RECOMMENDATIONS**

Staff has reviewed the application and exception request and has determined the impacts associated with the proposal to be minor for the proposed development. Staff recommends approval for this exception request and if the Board wishes to approve this request, staff recommends the following conditions be incorporated into the approval:

1. The applicant must obtain all other necessary federal, state, and local permits as required for the project, including a building permit if necessary; and
2. The submittal of a mitigation plan equaling one planting unit be submitted to the Stormwater and Resource Protection Division; and
3. A surety of \$500 be submitted in a form acceptable to the James City County Attorney's Office to guarantee the mitigation plantings; and
4. This exception request approval shall become null and void if construction has not begun by July 14, 2022; and
5. Written requests for an extension to an exception shall be submitted to the Stormwater and Resource Protection Division no later than June 2, 2022, six weeks prior to the expiration date.

TAL/md  
CBPA21-83\_114ConstAve

Attachments:

1. Resolution
2. Site Plan

## RESOLUTION

CASE NO. CBPA 21-0083. 114 CONSTANCE AVENUE

### JAMES CITY COUNTY CHESAPEAKE BAY PRESERVATION ORDINANCE EXCEPTION

WHEREAS, Acelution, Inc., on behalf of Mr. Stephen Smith and Mrs. Jessica Smith (the “Applicants”), has applied to the Chesapeake Bay Board of James City County (the “Board”) on July 14, 2021, to request an exception to use the Resource Protection Area (the “RPA”) on a parcel of property identified as James City County Real Estate Tax Map Parcel No. 4730500026 and further identified as 114 Constance Avenue (the “Property”) as set forth in the application CBPA 21-0083 for the purpose of construction of a landing; and

WHEREAS, the Board has listened to the arguments presented and has carefully considered all evidence entered into the record.

NOW, THEREFORE, BE IT RESOLVED that the Chesapeake Bay Board of James City County, Virginia, following a public hearing, by a majority vote of its members FINDS that:

1. The exception request is the minimum necessary to afford relief.
2. Granting the exception will not confer upon the Applicants any special privileges denied by Chapter 23, Chesapeake Bay Preservation, of the James City County Code, to other property owners similarly situated in the vicinity.
3. The exception request will be in harmony with the purpose and intent of Chapter 23 of the James City County Code and is not of substantial detriment to water quality.
4. The exception request is not based on conditions or circumstances that are self-created or self-imposed, nor does the request arise from conditions or circumstances either permitted or non-conforming that are related to adjacent parcels.
5. Reasonable and appropriate conditions are hereby imposed, as set forth below, which will prevent the exception request from causing a degradation of water quality.
6. In granting this exception, the following conditions are hereby imposed to prevent this exception request from causing degradation of water quality:
  - a. The applicants must obtain all other necessary federal, state, and local permits as required for the project, including a building permit if necessary; and
  - b. The submittal of a mitigation plan equaling one planting unit be submitted to the Stormwater and Resource Protection Division; and
  - c. A surety of \$500 be submitted in a form acceptable to the James City County Attorney’s Office to guarantee the mitigation plantings; and

- d. This exception request approval shall become null and void if construction has not begun by July 14, 2022; and
- e. Written requests for an extension to an exception shall be submitted to the Stormwater and Resource Protection Division no later than June 2, 2022, six weeks prior to the expiration date.

---

David Gussman  
Chair, Chesapeake Bay Board

---

Michael D. Woolson  
Secretary to the Board

Adopted by the Chesapeake Bay Board of James City County, Virginia, this 14th day of July, 2021.

CBPA21-83\_114ConstAve-res





**General Services**  
107 Tewning Road  
Williamsburg, VA 23188  
P: 757-259-4080  
General.Services@jamescitycountyva.gov  
[jamescitycountyva.gov](http://jamescitycountyva.gov)

**Capital Projects**  
107 Tewning Road  
Williamsburg, VA 23188  
757-259-4080

**Fleet**  
103 Tewning Road  
Williamsburg, VA 23188  
757-259-4122

**Stormwater and  
Resource Protection**  
101-E Mounts Bay Road  
Williamsburg, VA 23185  
757-253-6670

**Facilities & Grounds**  
113 Tewning Road  
Williamsburg, VA 23188  
757-259-4080

**Solid Waste**  
1204 Jolly Pond Road  
Williamsburg, VA 23188  
757-565-0971

June 23, 2021

RE: CBPA 21-0083  
114 Constance Avenue  
Landing

Dear Adjacent Property Owner:

In accordance with State and County Codes, this letter is to notify you that a request has been filed with the James City County Chesapeake Bay Board by Ms. Brittany Hulstine, Acelution, Inc. on behalf of Mr. Stephen Smith and Mrs. Jessica Smith for encroachment into the Resource Protection Area (RPA) buffer for construction of a landing. The project is located at 114 Constance Avenue and further identified as JCC Parcel No. 4730500026.

A complete description, plan and other information are on file in the Stormwater and Resource Protection Division and are available for inspection during normal business hours, should anyone desire to review them.

The Chesapeake Bay Board will hold an advertised public hearing on **Wednesday, July 14, 2021 at 5:00 p.m.**, in the Board Room of Building F, 101 Mounts Bay Road, James City County, Virginia, at which time you may request to speak on the above referenced project.

Sincerely,

*Michael D. Woolson*

Michael D. Woolson  
Chesapeake Bay Board Secretary  
757-253-6823  
michael.woolson@jamescitycountyva.gov

cc: Acelution, Inc.  
Attn: Ms. Brittany Hulstine

MDW: jep

Mailing List for: CBPA-21-0083-114 Constance Avenue:- Deck

Owner: 4730500026

Smith, Stephen T & Jessica D  
114 Constance Avenue  
Williamsburg, VA 23185-3145

4730500027 - 116 Constance Avenue

Parks, James N, Trustee & Ruth D, Trustee  
1201 Fearrington Post  
Pittsboro, NC 27312-5025

4730500025

Haywood, John C  
112 Constance Avenue  
Williamsburg, VA 23185-3145

Contractor:

Acelution, Inc.  
Attn: Ms. Brittany Hulstine  
632 Hampton Highway  
Yorktown, VA 23693-4100

4730500031

Flynn, Francis Marion, II, Trustee & Virginia O,  
Trustee  
109 Godspeed Lane  
Williamsburg, VA 23185-3171

4730500030

Pruitt, James S & Jessica S  
107 Godspeed Lane  
Williamsburg, VA 23185-3171



## **PUBLIC HEARING NOTICE**

THE WETLANDS BOARD AND THE CHESAPEAKE BAY BOARD OF JAMES CITY COUNTY, VIRGINIA, WILL HOLD PUBLIC HEARINGS ON **WEDNESDAY, JULY 14, 2021 AT 5 P.M.** IN THE COUNTY GOVERNMENT CENTER BOARD ROOM OF BUILDING F, 101 MOUNTS BAY ROAD, JAMES CITY COUNTY, VIRGINIA.

THE WETLANDS BOARD WILL CONSIDER THE FOLLOWING CASE:

WJPA 21-0027/VMRC-2021-1060: Water's Edge Construction, on behalf of Mr. J. Barry Davidson, Jr. and Mrs. Laura Davidson, and Mr. Richard Costello and Mrs. Nina Costello, has applied for a wetlands permit for the construction of an offshore sill with beach nourishment and the repair of a rip rap revetment at 10016 and 10020 Sycamore Landing Road, JCC Parcel ID No. 0720400002 and JCC Parcel ID No. 0720400004.

THE CHESAPEAKE BAY BOARD WILL CONSIDER THE FOLLOWING CASES:

CBPA 21-0075: Water's Edge Construction, on behalf of Mr. David and Mrs. Kim Lambey have filed an exception request for encroachments into the RPA buffer for bank grading at 10006 Sycamore Landing Road, JCC Parcel ID No. 0720100002.

CBPA 21-0083: Acelution, Inc., on behalf of Mr. Stephen and Mrs. Jessica Smith, has filed an exception request for encroachments into the RPA buffer for the construction of a landing at 114 Constance Avenue, JCC Parcel ID No. 4730500026.

CBPA 21-0087: Mr. Harold Breeden has filed an exception request for encroachments into the RPA buffer for the addition of fill material at 10007 Sycamore Landing Road, JCC Parcel ID No. 0720400011.

Appeals from decisions under the Chesapeake Bay Preservation Ordinance may also be heard.

The applications and plans are on file and may be viewed during normal office hours in the Stormwater and Resource Protection Division, 101-E Mounts Bay Road, James City County, Virginia.

**NOT FOR PUBLICATION**

DISPLAY: WEDNESDAY – JULY 7, 2021 and JUNE 30, 2021.  
ACCOUNT NO. CU00015112  
VIRGINIA GAZETTE  
1/8 PAGE, VERTICAL, B/W  
CARD # x9941

COPIES: PLANNING  
ASSISTANT COUNTY ATTORNEY  
WETLANDS/CHESAPEAKE BAY BOARD MEMBERS



**ITEM SUMMARY**

DATE: 7/14/2021  
TO: Chesapeake Bay Board  
FROM: Trevor Long, Watershed Planner  
SUBJECT: Case No. CBPA 21-0087 : 10007 Sycamore Landing Road

---

CBPA 21-0087: Mr. Harold Breeden has filed an exception request for encroachments into the RPA buffer for the addition of fill material at 10007 Sycamore Landing Road, JCC Parcel ID No. 0720400011.

**ATTACHMENTS:**

	Description	Type
☐	Staff Report	Staff Report
☐	Resolution	Resolution
☐	Site Plan	Exhibit
☐	Adjacent Property Owner Letter	Backup Material
☐	Adjacent Property Owner List	Backup Material
☐	Public Advertisement	Backup Material

**REVIEWERS:**

Department	Reviewer	Action	Date
Chesapeake Bay Group	Woolson, Michael	Approved	7/6/2021 - 10:46 PM
Chesapeake Bay Group	Small, Toni	Approved	7/7/2021 - 7:53 AM
Publication Management	Daniel, Martha	Approved	7/7/2021 - 8:48 AM
Chesapeake Bay Group	Secretary, ChesBay	Approved	7/7/2021 - 4:00 PM

**CHESAPEAKE BAY BOARD EXCEPTION No. CBPA 21-0087. 10007 Sycamore Landing Road Staff Report for the July 14, 2021, Chesapeake Bay Board Public Hearing**

---

*This staff report is prepared by the James City County Stormwater and Resource Protection to provide information to the Chesapeake Bay Board to assist them in making a recommendation on this assessment. It may be useful to members of the general public interested in this assessment.*

---

**EXISTING SITE DATA AND INFORMATION**

Applicant: Mr. Harold Breeden  
Agent: None  
Location: 10007 Sycamore Landing Road  
Parcel Identification No.: 0720400011  
Parcel: Sycamore Landing  
Lot Size: 1.53 acres  
Area of Lot in Resource Protection Area (RPA): 1.06 acres +/- (69%)  
Watershed: Ware Creek (HUC YO 62)  
Floodplain: Zone AE - Base flood elevation determined at 7 feet  
Proposed Activity: Addition of fill material  
Impervious Cover: 2,500 square feet  
RPA Encroachment: 2,500 square feet, landward 50-foot RPA  
Staff Contact: Trevor A. Long, Watershed Planner Phone: 253-6789

**BRIEF SUMMARY AND DESCRIPTION OF ACTIVITIES**

Mr. Harold Breeden has applied for a Chesapeake Bay Exception for encroachments into the RPA buffer for the addition of fill material on property located at 10007 Sycamore Landing Road within the Ware Creek watershed. The property is further identified as James City County Tax Map Parcel No. 0720400011. The parcel was platted in 1957, prior the adoption of the Chesapeake Bay Preservation Ordinance in 1990.

The total lot size of this property is 1.53 acres, of which 69% is located within the RPA. There is a shoreline erosion project, permitted by the James City County Wetlands Board and Chesapeake Bay Board occurring on this same street. The applicant is proposing to utilize the fill dirt associated with the shoreline erosion project to fill approximately 2,500 square feet of subsided land within the landward 50-foot RPA. Required mitigation of this amount of impacts to the RPA equals the plantings of seven planting units (seven canopy trees, 14 understory trees, and 21 shrubs). Due to the fact that the RPA is proposed to be disturbed and regraded, the mitigation required shall be replanted back in the disturbed area.

**STAFF EVALUATION**

Staff has evaluated the application and exception request for the addition of fill. This application meets the Ordinance conditions in Sections 23-11 and 23-14 and should be heard by the Board because the addition of fill is not a permitted use.

## **CONSIDERATION BY THE CHESAPEAKE BAY BOARD**

The Board may grant exceptions to Section 23-7 if the application meets the following five conditions:

1. The exception request is the minimum necessary to afford relief; and
2. Granting the exception will not confer upon the Applicants any special privileges denied by Chapter 23, Chesapeake Bay Preservation, of the James City County Code, to other property owners similarly situated in the vicinity; and
3. The exception request will be in harmony with the purpose and intent of Chapter 23 of the James City County Code and is not of substantial detriment to water quality; and
4. The exception request is not based on conditions or circumstances that are self-created or self-imposed, nor does the request arise from conditions or circumstances, either permitted or non-conforming that are related to adjacent parcels; and
5. Reasonable and appropriate conditions are imposed which will prevent the exception request from causing a degradation of water quality.

## **STAFF RECOMMENDATIONS**

Staff has reviewed the application and exception request and has determined the impacts associated with the proposal to be moderate for the proposed development. Staff recommends approval for this exception request and if the Board wishes to approve this request, staff recommends the following conditions be incorporated into the approval:

1. The applicant must obtain all other necessary federal, state, and local permits, as required for the project, including an Erosion and Sediment Control Plan and a Land Disturbing Permit; and
2. The submittal of a mitigation plan equaling seven planting units be submitted to the Stormwater and Resource Protection Division; and
3. A surety of \$3,000 be submitted in a form acceptable to the James City County Attorney's Office to guarantee the mitigation plantings; and
4. This exception request approval shall become null and void if construction has not begun by July 14, 2022; and
5. Written requests for an extension to an exception shall be submitted to the Stormwater and Resource Protection Division no later than June 2, 2022, six weeks prior to the expiration date.

TAL/md  
CBPA21-87\_1007SycLdgRd

Attachments:

1. Resolution
2. Site Plan

## RESOLUTION

CASE NO. CBPA 21-0087. 10007 SYCAMORE LANDING ROAD

### JAMES CITY COUNTY CHESAPEAKE BAY PRESERVATION ORDINANCE EXCEPTION

WHEREAS, Mr. Harold Breeden (the “Applicant”) has applied to the Chesapeake Bay Board of James City County (the “Board”) on July 14, 2021, to request an exception to use the Resource Protection Area (the “RPA”) on a parcel of property identified as James City County Real Estate Tax Map Parcel No. 0720400011 and further identified as 10007 Sycamore Landing Road (the “Property”) as set forth in the application CBPA 21-0087 for the purpose of addition of fill material; and

WHEREAS, the Board has listened to the arguments presented and has carefully considered all evidence entered into the record.

NOW, THEREFORE, BE IT RESOLVED that the Chesapeake Bay Board of James City County, Virginia, following a public hearing, by a majority vote of its members FINDS that:

1. The exception request is the minimum necessary to afford relief.
2. Granting the exception will not confer upon the Applicant any special privileges denied by Chapter 23, Chesapeake Bay Preservation, of the James City County Code, to other property owners similarly situated in the vicinity.
3. The exception request will be in harmony with the purpose and intent of Chapter 23 of the James City County Code and is not of substantial detriment to water quality.
4. The exception request is not based on conditions or circumstances that are self-created or self-imposed, nor does the request arise from conditions or circumstances either permitted or non-conforming that are related to adjacent parcels.
5. Reasonable and appropriate conditions are hereby imposed, as set forth below, which will prevent the exception request from causing a degradation of water quality.
6. In granting this exception, the following conditions are hereby imposed to prevent this exception request from causing degradation of water quality:
  - a. The applicant must obtain all other necessary federal, state, and local permits as required for the project, including a building permit, erosion and sediment control plan, and a land disturbing permit if necessary; and

- b. The submittal of a mitigation plan equaling seven planting units be submitted to the Stormwater and Resource Protection Division; and
- c. A surety of \$3,000 be submitted in a form acceptable to the James City County Attorney's Office to guarantee the mitigation plantings (seven canopy trees, 14 understory trees, and 21 shrubs); and
- d. This exception request approval shall become null and void if construction has not begun by July 14, 2022; and
- e. Written requests for an extension to an exception shall be submitted to the Stormwater and Resource Protection Division no later than June 2, 2022, six weeks prior to the expiration date.

\_\_\_\_\_  
David Gussman  
Chair, Chesapeake Bay Board

\_\_\_\_\_  
Michael D. Woolson  
Secretary to the Board

Adopted by the Chesapeake Bay Board of James City County, Virginia, this 14th day of July, 2021.

CBPA21-87\_10007SycLdgRd-res

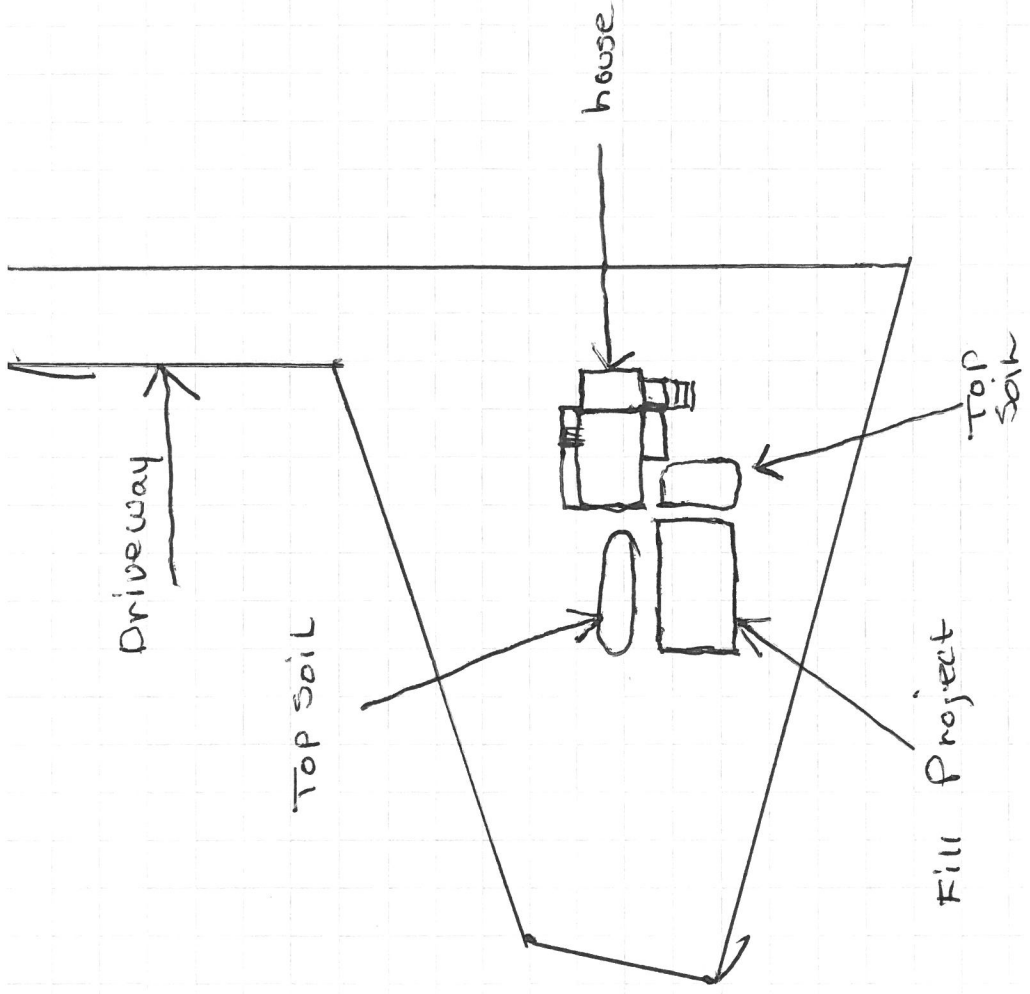

Front View

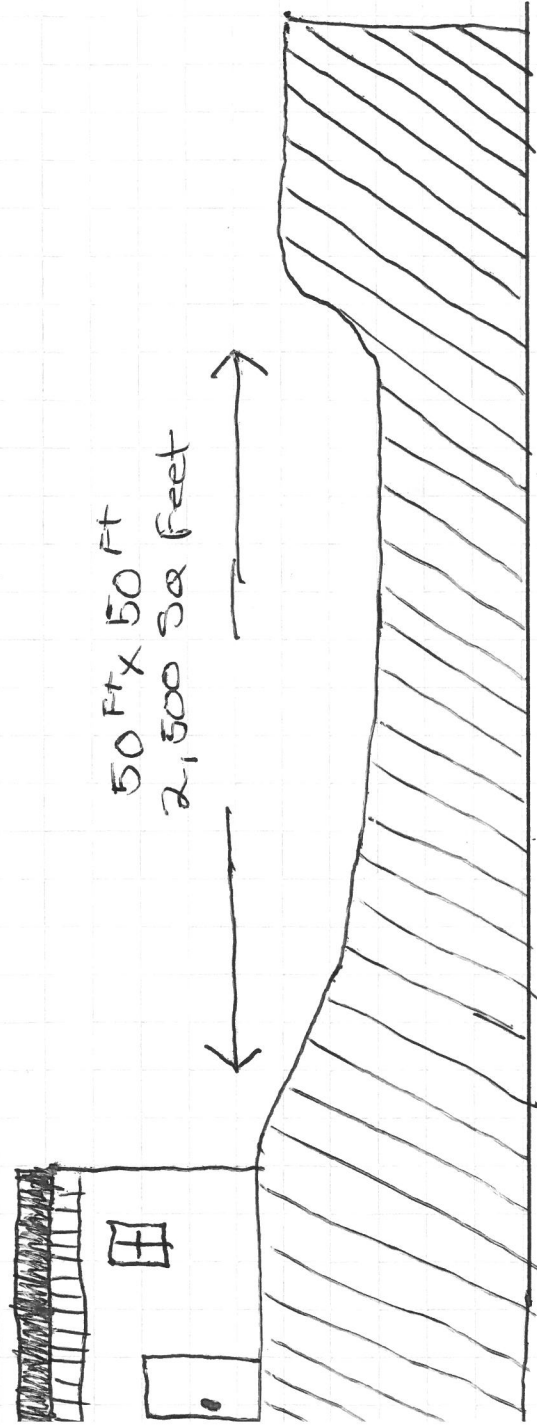

Side View

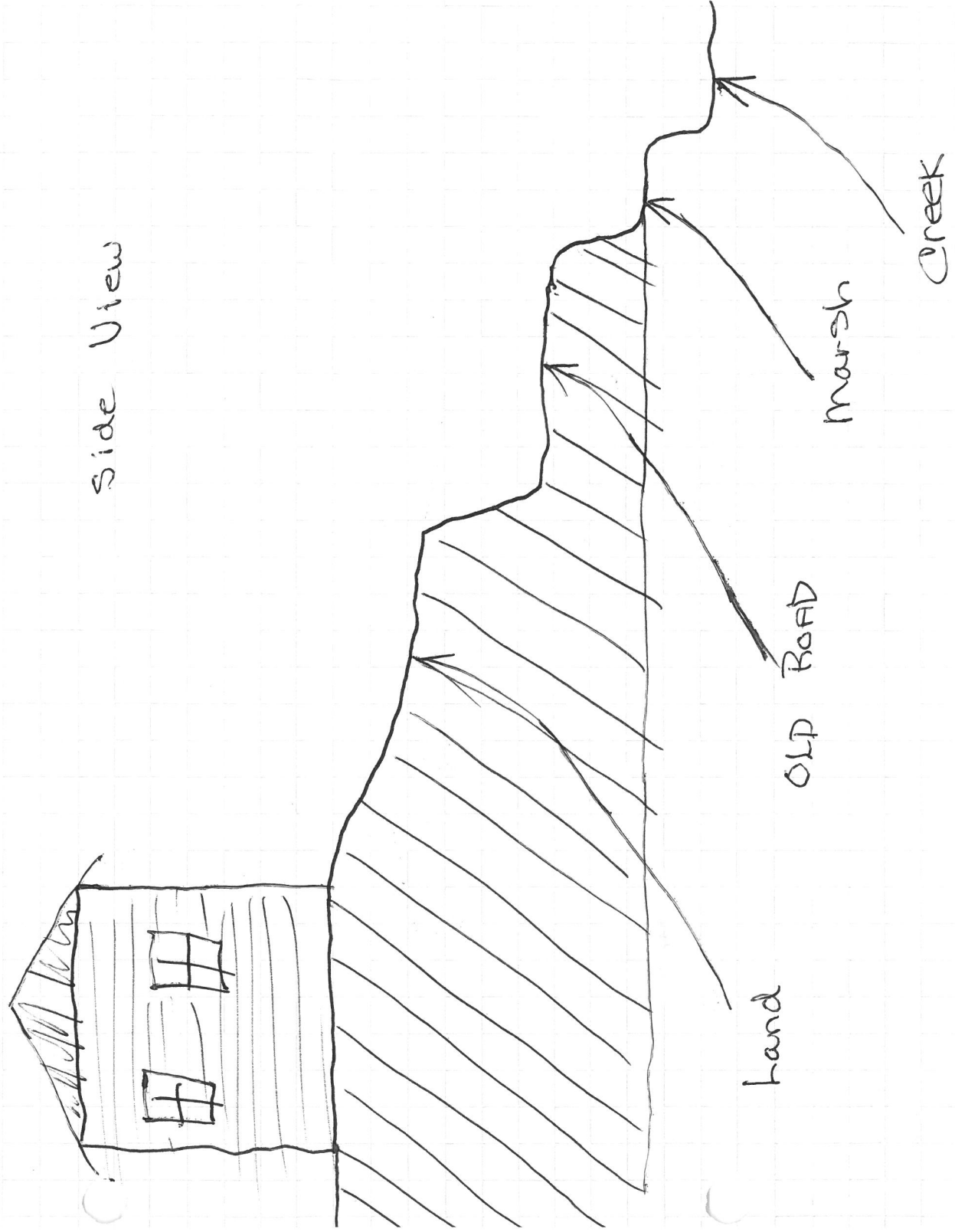

Hand

Old Road

Marsh

Creek



**General Services**  
107 Tewning Road  
Williamsburg, VA 23188  
P: 757-259-4080  
General.Services@jamescitycountyva.gov  
[jamescitycountyva.gov](http://jamescitycountyva.gov)

**Capital Projects**  
107 Tewning Road  
Williamsburg, VA 23188  
757-259-4080

**Fleet**  
103 Tewning Road  
Williamsburg, VA 23188  
757-259-4122

**Stormwater and  
Resource Protection**  
101-E Mounts Bay Road  
Williamsburg, VA 23185  
757-253-6670

**Facilities & Grounds**  
113 Tewning Road  
Williamsburg, VA 23188  
757-259-4080

**Solid Waste**  
1204 Jolly Pond Road  
Williamsburg, VA 23188  
757-565-0971

June 23, 2021

RE: CBPA 21-0087  
10007 Sycamore Landing Road  
Addition of Fill Dirt

Dear Adjacent Property Owner:

In accordance with State and County Codes, this letter is to notify you that a request has been filed with the James City County Chesapeake Bay Board by Mr. Harold Breeden for encroachment into the Resource Protection Area (RPA) buffer for the addition of fill dirt. The project is located at 10007 Sycamore Landing Road and further identified as JCC Parcel No. 0720400011.

A complete description, plan and other information are on file in the Stormwater and Resource Protection Division and are available for inspection during normal business hours, should anyone desire to review them.

The Chesapeake Bay Board will hold an advertised public hearing on **Wednesday, July 14, 2021 at 5:00 p.m.**, in the Board Room of Building F, 101 Mounts Bay Road, James City County, Virginia, at which time you may request to speak on the above referenced project.

Sincerely,

*Michael D. Woolson*

Michael D. Woolson  
Chesapeake Bay Board Secretary  
757-253-6823  
michael.woolson@jamescitycountyva.gov

MDW: jep



Mailing List for: CBPA-21-0087 – 10007 Sycamore Landing Road:- Addition of Fill

Owner: 0720400011

Breeden, Harold N, Jr.  
10007 Sycamore Landing Road  
Williamsburg, VA 23188-1255

0720500001

Williams, Thomas H, Sr. & Shirley L  
10005 Sycamore Landing Road  
Williamsburg, VA 23188-1255

0720400008 – 10021 Sycamore Landing Road

Cody, Phyllis J, Trustee  
4613 Ware Creek Road  
Williamsburg, VA 23188-1127

0720400001- 10010 Sycamore Landing Road

Amason, Deric C & Andrea V  
6322 South Springs Circle  
Clifton, VA 20124-2461

0720400013 – 10015 Sycamore Landing Road

Miller, Jeffrey & Anne  
10025 Sycamore Landing Road  
Williamsburg, VA 23188-1255

0720100002

Lambey, David O, Trustee & Kim C, Trustee  
10006 Sycamore Landing Road  
Williamsburg, VA 23188-1254

0720400010

Smith, Darlene W  
10009 Sycamore Landing Road  
Williamsburg, VA 23188-1255

0630100005 – 9800 Six Mount Zion Road

SCP-JTL Stonehouse Owner 2, LLC  
4807 W Lovers Lane, Floor 2  
Dallas, Tx 75209-3137



## **PUBLIC HEARING NOTICE**

THE WETLANDS BOARD AND THE CHESAPEAKE BAY BOARD OF JAMES CITY COUNTY, VIRGINIA, WILL HOLD PUBLIC HEARINGS ON **WEDNESDAY, JULY 14, 2021 AT 5 P.M.** IN THE COUNTY GOVERNMENT CENTER BOARD ROOM OF BUILDING F, 101 MOUNTS BAY ROAD, JAMES CITY COUNTY, VIRGINIA.

THE WETLANDS BOARD WILL CONSIDER THE FOLLOWING CASE:

WJPA 21-0027/VMRC-2021-1060: Water's Edge Construction, on behalf of Mr. J. Barry Davidson, Jr. and Mrs. Laura Davidson, and Mr. Richard Costello and Mrs. Nina Costello, has applied for a wetlands permit for the construction of an offshore sill with beach nourishment and the repair of a rip rap revetment at 10016 and 10020 Sycamore Landing Road, JCC Parcel ID No. 0720400002 and JCC Parcel ID No. 0720400004.

THE CHESAPEAKE BAY BOARD WILL CONSIDER THE FOLLOWING CASES:

CBPA 21-0075: Water's Edge Construction, on behalf of Mr. David and Mrs. Kim Lambey have filed an exception request for encroachments into the RPA buffer for bank grading at 10006 Sycamore Landing Road, JCC Parcel ID No. 0720100002.

CBPA 21-0083: Acelution, Inc., on behalf of Mr. Stephen and Mrs. Jessica Smith, has filed an exception request for encroachments into the RPA buffer for the construction of a landing at 114 Constance Avenue, JCC Parcel ID No. 4730500026.

CBPA 21-0087: Mr. Harold Breeden has filed an exception request for encroachments into the RPA buffer for the addition of fill material at 10007 Sycamore Landing Road, JCC Parcel ID No. 0720400011.

Appeals from decisions under the Chesapeake Bay Preservation Ordinance may also be heard.

The applications and plans are on file and may be viewed during normal office hours in the Stormwater and Resource Protection Division, 101-E Mounts Bay Road, James City County, Virginia.

**NOT FOR PUBLICATION**

DISPLAY: WEDNESDAY – JULY 7, 2021 and JUNE 30, 2021.  
ACCOUNT NO. CU00015112  
VIRGINIA GAZETTE  
1/8 PAGE, VERTICAL, B/W  
CARD # x9941

COPIES: PLANNING  
ASSISTANT COUNTY ATTORNEY  
WETLANDS/CHESAPEAKE BAY BOARD MEMBERS

**ITEM SUMMARY**

DATE: 7/14/2021  
TO: Chesapeake Bay Board  
FROM: Trevor Long, Watershed Planner  
SUBJECT: CBPA 21-0075 : 10006 Sycamore Landing Road

---

CBPA 21-0075: Waters Edge Construction, on behalf of Mr. David and Mrs. Kim Lambey have filed an exception request for encroachments into the RPA buffer for bank grading at 10006 Sycamore Landing Road, JCC Parcel ID No. 0720100002.

**ATTACHMENTS:**

	Description	Type
☐	Staff Report	Staff Report
☐	Resolution	Resolution
☐	Mitigation Plans	Backup Material
☐	Adjacent Property Owner Letter	Backup Material
☐	Adjacent Property Owner List	Backup Material
☐	Public Advertisement	Backup Material

**REVIEWERS:**

Department	Reviewer	Action	Date
Chesapeake Bay Group	Woolson, Michael	Approved	7/6/2021 - 10:46 PM
Chesapeake Bay Group	Small, Toni	Approved	7/7/2021 - 7:52 AM
Publication Management	Daniel, Martha	Approved	7/7/2021 - 8:38 AM
Chesapeake Bay Group	Secretary, ChesBay	Approved	7/7/2021 - 4:00 PM

**CHESAPEAKE BAY BOARD EXCEPTION No. CBPA 21-0075. 10006 Sycamore Landing Road  
Staff Report for the July 14, 2021, Chesapeake Bay Board Public Hearing**

---

*This staff report is prepared by the James City County Stormwater and Resource Protection to provide information to the Chesapeake Bay Board to assist them in making a recommendation on this assessment. It may be useful to members of the general public interested in this assessment.*

---

**EXISTING SITE DATA AND INFORMATION**

Applicants: Mr. David and Ms. Kim Lambey

Agent: Mr. Daniel Winall, Waters Edge Construction

Location: 10006 Sycamore Landing Road

Parcel Identification No.: 0720100002

Parcel: Lot 1 & 2 Block A, Lot 1 & 2 Block B

Lot Size: 1.15 acres

Area of Lot in Resource Protection Area (RPA): 0.40 acres +/- (35%)

Watershed: York River (HUC YO 63)

Floodplain: Zone VE - Base flood elevation determined at 17 feet

Proposed Activity: Bank grading associated with Virginia Marine Resources Commission (VMRC) permit #2019-2163

Impervious Cover: 1,000 square feet

RPA Encroachment: 1,000 square feet, seaward 50-foot RPA

Staff Contact: Trevor A. Long, Watershed Planner Phone: 253-6789

**BRIEF SUMMARY AND DESCRIPTION OF ACTIVITIES**

Mr. Daniel Winall, Waters Edge Construction, has applied for a Chesapeake Bay Exception on behalf of Mr. David and Ms. Kim Lambey for encroachments into the RPA buffer for bank grading on property located at 10006 Sycamore Landing Road within the York River watershed. The property is further identified as James City County Tax Map Parcel No. 0720100002. The parcel was platted in 1926, prior to the adoption of the Chesapeake Bay Preservation Ordinance in 1990.

The total lot size of this property is 1.15 acres, of which 35% is located within the RPA. The James City County Wetlands Board approved WJPA-19-0048 for the construction of a marsh toe sill with beach nourishment and a revetment. The applicants are proposing bank grading in association with this living shoreline equaling approximately 1,000 square feet of fill within the seaward 50-foot RPA. To mitigate for the proposed grading and impacts to the RPA, County mitigation requirements are to revegetate the slope with 33 native shrubs (three planting units).

## **STAFF EVALUATION**

Staff has evaluated the application and exception request for the bank grading. This application meets the Ordinance conditions in Sections 23-11 and 23-14 and should be heard by the Board because the grading of a bank is not a permitted use and occurs within the seaward 50-foot RPA.

## **CONSIDERATION BY THE CHESAPEAKE BAY BOARD**

The Board may grant exceptions to Section 23-7 if the application meets the following five conditions:

1. The exception request is the minimum necessary to afford relief; and
2. Granting the exception will not confer upon the Applicants any special privileges denied by Chapter 23, Chesapeake Bay Preservation, of the James City County Code, to other property owners similarly situated in the vicinity; and
3. The exception request will be in harmony with the purpose and intent of Chapter 23 of the James City County Code and is not of substantial detriment to water quality; and
4. The exception request is not based on conditions or circumstances that are self-created or self-imposed, nor does the request arise from conditions or circumstances, either permitted or non-conforming that are related to adjacent parcels; and
5. Reasonable and appropriate conditions are imposed which will prevent the exception request from causing a degradation of water quality.

## **STAFF RECOMMENDATIONS**

Staff has reviewed the application and exception request and has determined the impacts associated with the proposal to be minor for the proposed development. Staff recommends approval for this exception request and if the Board wishes to approve this request, staff recommends the following conditions be incorporated into the approval:

1. The applicants must obtain all other necessary federal, state, and local permits as required for the project, including a building permit if necessary; and
2. The submittal of a mitigation plan equaling three planting units be submitted to the Stormwater and Resource Protection Division; and
3. A surety of \$1,000 be submitted in a form acceptable to the James City County Attorney's Office to guarantee the mitigation plantings; and
4. This exception request approval shall become null and void if construction has not begun by July 14, 2022; and
5. Written requests for an extension to an exception shall be submitted to the Stormwater and Resource Protection Division no later than June 2, 2022 six weeks prior to the expiration date.

TAL/md  
CBPA21-75\_10006SycLdgRd

### Attachments:

1. Resolution
2. Site Plan

## RESOLUTION

CASE NO. CBPA 21-0075. 10006 SYCAMORE LANDING ROAD

### JAMES CITY COUNTY CHESAPEAKE BAY PRESERVATION ORDINANCE EXCEPTION

WHEREAS, Waters Edge Construction on behalf of Mr. David and Mrs. Kim Lambey (the “Applicants”) has applied to the Chesapeake Bay Board of James City County (the “Board”) on July 14, 2021, to request an exception to use the Resource Protection Area (the “RPA”) on a parcel of property identified as James City County Real Estate Tax Map Parcel No. 0720100002 and further identified as 10006 Sycamore Landing Road (the “Property”) as set forth in the application CBPA 21-0075 for the purpose of bank grading; and

WHEREAS, the Board has listened to the arguments presented and has carefully considered all evidence entered into the record.

NOW, THEREFORE, BE IT RESOLVED that the Chesapeake Bay Board of James City County, Virginia, following a public hearing, by a majority vote of its members FINDS that:

1. The exception request is the minimum necessary to afford relief.
2. Granting the exception will not confer upon the Applicants any special privileges denied by Chapter 23, Chesapeake Bay Preservation, of the James City County Code, to other property owners similarly situated in the vicinity.
3. The exception request will be in harmony with the purpose and intent of Chapter 23 of the James City County Code and is not of substantial detriment to water quality.
4. The exception request is not based on conditions or circumstances that are self-created or self-imposed, nor does the request arise from conditions or circumstances either permitted or non-conforming that are related to adjacent parcels.
5. Reasonable and appropriate conditions are hereby imposed, as set forth below, which will prevent the exception request from causing a degradation of water quality.
6. In granting this exception, the following conditions are hereby imposed to prevent this exception request from causing degradation of water quality:
  - a. The applicants must obtain all other necessary federal, state, and local permits as required for the project, including a building permit if necessary; and
  - b. The submittal of a mitigation plan equaling three shrubs be submitted to the Stormwater and Resource Protection Division; and
  - c. A surety of \$250 be submitted in a form acceptable to the James City County Attorney’s Office to guarantee the mitigation plantings; and

- d. This exception request approval shall become null and void if construction has not begun by July 14, 2022; and
- e. Written requests for an extension to an exception shall be submitted to the Stormwater and Resource Protection Division no later than June 2, 2022, six weeks prior to the expiration date.

---

David Gussman  
Chair, Chesapeake Bay Board

---

Michael D. Woolson  
Secretary to the Board

Adopted by the Chesapeake Bay Board of James City County, Virginia, this 14th day of July, 2021.

CBPA21-75\_10006SycLdgRd-res





YORK RIVER  
FLOODS

RECEIVED  
DEC 27 2019  
MARINE RESOURCES  
COMMISSION

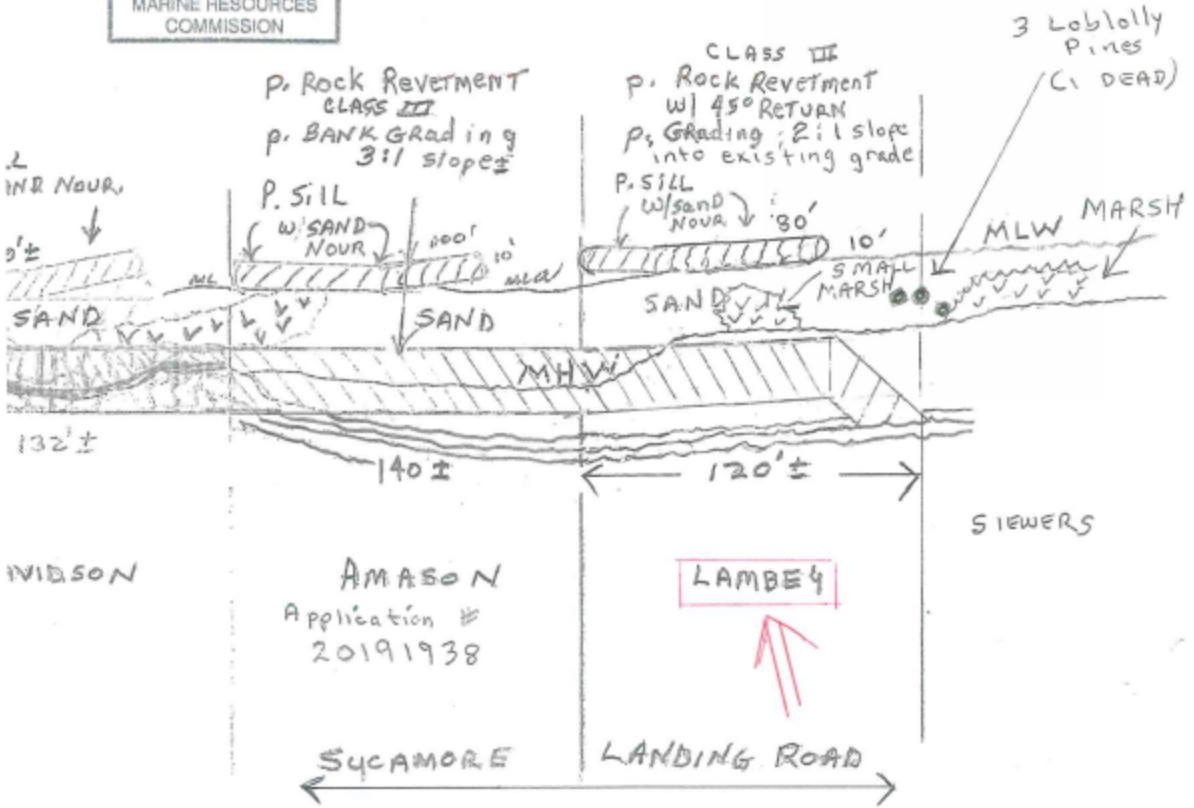



**General Services**  
107 Tewning Road  
Williamsburg, VA 23188  
P: 757-259-4080  
General.Services@jamescitycountyva.gov  
[jamescitycountyva.gov](http://jamescitycountyva.gov)

<b>Capital Projects</b> 107 Tewning Road Williamsburg, VA 23188 757-259-4080	<b>Fleet</b> 103 Tewning Road Williamsburg, VA 23188 757-259-4122	<b>Stormwater and Resource Protection</b> 101-E Mounts Bay Road Williamsburg, VA 23185 757-253-6670	<b>Facilities &amp; Grounds</b> 113 Tewning Road Williamsburg, VA 23188 757-259-4080	<b>Solid Waste</b> 1204 Jolly Pond Road Williamsburg, VA 23188 757-565-0971
---	--	--	---	--

June 23, 2021

RE: CBPA 21-0075  
10006 Sycamore Landing Road  
Bank Grading

Dear Adjacent Property Owner:

In accordance with State and County Codes, this letter is to notify you that a request has been filed with the James City County Chesapeake Bay Board by Mr. Daniel Winall, Waters Edge Construction on behalf of Mr. David Lambey and Mrs. Kim Lambey for encroachment into the Resource Protection Area (RPA) buffer for bank grading. The project is located at 10006 Sycamore Landing Road and further identified as JCC Parcel No. 0720100002.

A complete description, plan and other information are on file in the Stormwater and Resource Protection Division and are available for inspection during normal business hours, should anyone desire to review them.

The Chesapeake Bay Board will hold an advertised public hearing on **Wednesday, July 14, 2021 at 5:00 p.m.**, in the Board Room of Building F, 101 Mounts Bay Road, James City County, Virginia, at which time you may request to speak on the above referenced project.

Sincerely,

*Michael D. Woolson*

Michael D. Woolson  
Chesapeake Bay Board Secretary  
757-253-6823  
michael.woolson@jamescitycountyva.gov

cc: Waters Edge Construction  
Attn: Mr. Daniel R. Winall

MDW: jep

Mailing List for: CBPA-21-0075–10006 Sycamore Landing Rd:- Stabilize Bank

Owner: 0720100002

Lambey, David O, Trustee & Kim C, Trustee  
10006 Sycamore Landing Road  
Williamsburg, VA 23188-1254

0720100003 – 9936 Sycamore Landing Road

Siewers, John C, II, Trustee  
109 Seneca Road  
Richmond, VA 23226-2331

0720400001 –10010 Sycamore Landing Road

Amason, Deric C & Andrea V  
6322 South Springs Circle  
Clifton, VA 20124-2461

0720400011

Breeden, Harold N, Jr.  
10007 Sycamore Landing Road  
Williamsburg, VA 23188-1255

Contractor:

Waters Edge Construction  
Mr. Daniel R. Winall  
PO. Box 352  
Toano, VA 23168-0352

0720500001

Williams, Thomas H, Sr. & Shirley L  
10005 Sycamore Landing Road  
Williamsburg, VA 23188-1255

0720500002

Richards, Russell Lee & Lee Turner  
10001 Sycamore Landing Road  
Williamsburg, VA 23188-1255



## **PUBLIC HEARING NOTICE**

THE WETLANDS BOARD AND THE CHESAPEAKE BAY BOARD OF JAMES CITY COUNTY, VIRGINIA, WILL HOLD PUBLIC HEARINGS ON **WEDNESDAY, JULY 14, 2021 AT 5 P.M.** IN THE COUNTY GOVERNMENT CENTER BOARD ROOM OF BUILDING F, 101 MOUNTS BAY ROAD, JAMES CITY COUNTY, VIRGINIA.

THE WETLANDS BOARD WILL CONSIDER THE FOLLOWING CASE:

WJPA 21-0027/VMRC-2021-1060: Water's Edge Construction, on behalf of Mr. J. Barry Davidson, Jr. and Mrs. Laura Davidson, and Mr. Richard Costello and Mrs. Nina Costello, has applied for a wetlands permit for the construction of an offshore sill with beach nourishment and the repair of a rip rap revetment at 10016 and 10020 Sycamore Landing Road, JCC Parcel ID No. 0720400002 and JCC Parcel ID No. 0720400004.

THE CHESAPEAKE BAY BOARD WILL CONSIDER THE FOLLOWING CASES:

CBPA 21-0075: Water's Edge Construction, on behalf of Mr. David and Mrs. Kim Lambey have filed an exception request for encroachments into the RPA buffer for bank grading at 10006 Sycamore Landing Road, JCC Parcel ID No. 0720100002.

CBPA 21-0083: Acelution, Inc., on behalf of Mr. Stephen and Mrs. Jessica Smith, has filed an exception request for encroachments into the RPA buffer for the construction of a landing at 114 Constance Avenue, JCC Parcel ID No. 4730500026.

CBPA 21-0087: Mr. Harold Breeden has filed an exception request for encroachments into the RPA buffer for the addition of fill material at 10007 Sycamore Landing Road, JCC Parcel ID No. 0720400011.

Appeals from decisions under the Chesapeake Bay Preservation Ordinance may also be heard.

The applications and plans are on file and may be viewed during normal office hours in the Stormwater and Resource Protection Division, 101-E Mounts Bay Road, James City County, Virginia.

**NOT FOR PUBLICATION**

DISPLAY: WEDNESDAY – JULY 7, 2021 and JUNE 30, 2021.  
ACCOUNT NO. CU00015112  
VIRGINIA GAZETTE  
1/8 PAGE, VERTICAL, B/W  
CARD # x9941

COPIES: PLANNING  
ASSISTANT COUNTY ATTORNEY  
WETLANDS/CHESAPEAKE BAY BOARD MEMBERS